

FABRICATION MANUAL

June 2024



HanStone



DISTINCTLY BEAUTIFUL. NATURALLY CANADIAN.

Created by the fusion of exceptional design, superior quartz and cutting-edge technology, HanStone Quartz weaves together intriguing patterns and colours inspired by the diverse Canadian landscape. The go-to choice of designers, architects and homeowners from coast to coast, HanStone Quartz is the next generation of stone surfaces.

FOR MORE INFORMATION VISIT:
HANSTONE.CA



TABLE OF CONTENTS

Introduction	4
Applications	5
Handling and Safety Statement	6
Safety Data Sheet	8
Material Inspection Checklist	15
Slab Identification Sticker	17
Fabrication and Safety Equipment	18
Material and Equipment Check	22
Fabrication Guidelines	23
Cutting Speeds	25
Corners	30
Seams	31
Mitered Edges	32
Lamination	33
Seaming Adhesives	34
Support	35
Cutouts	38
Appliances	40
Clean Up	48

INTRODUCTION

HanStone Quartz is an innovative new product that combines natural quartz, one of nature's hardest materials, with high quality polymer resin and pigment to produce a durable yet luxurious stone surface. We source various types, sizes and colors of quartz crystals from around the world, which provide the desired hue, feel and design, and capture the spirit and essence of natural colors. Unlike granite and many other surfaces, HanStone Quartz is nonporous and requires no sealing. In addition to being even more durable than granite, HanStone Quartz is also stain-resistant, heat-resistant and easy to maintain. It has also been tested and certified by the National Sanitation for Food Safety and Food Contact under the NSF 51 Certification, and is backed by a Commercial 10-Year Lifetime Warranty and a Residential Lifetime Limited Warranty.

These qualities have made HanStone Quartz a premier choice among builders around the world. For homeowners, it's an ideal surface for kitchen countertops, bathroom vanities, bar tops and other surfaces. It's also perfect for high-traffic areas such as offices, banks, hotels and restaurants, where applications can also include walls, reception areas, serving areas, table tops, and much more.

If you're looking for a surface that is safe for food preparation and easy to maintain, yet will maintain its luster and natural beauty, you'll find HanStone Quartz to be the perfect choice!

HANSTONE CANADA
2860 Innovation Drive
London, ON N6M 0C5

info@hanstone.ca

The information contained here is deemed reliable; however, none of the contents—including but not limited to the recommendations, pictures, techniques, and or instructions – is to be conceived as implying legal liability of fitness for a particular purpose, any other type of warranty, or being exhaustive or conclusive in its coverage and nature of information. Per each user's specific application, all necessary measures and precaution must be taken in order to confirm and test the adequacy for such needs or application. The information contained herein is strictly for purposes of reference and as such, Hyundai L&C LLC and its affiliates assume no liability for its accuracy or suitability or the use of such information for products other than HanStone Quartz surfaces.

APPLICATIONS

HanStone Quartz can be used in several design applications, such as kitchen countertops, benches, islands, peninsulas; bathroom vanities, shower walls and niches, bath and tub surrounds; table tops, furniture, mantles, window sills, wall coverings and thresholds, etc.

Commercial uses such as healthcare facilities, restaurants, offices; including conference tables, reception and desktops, countertops and credenzas, lobby/interior walls, food preparation areas, laboratories, and inlays.

HanStone Quartz is not suitable for outdoor or exterior applications, or areas that it will be exposed to direct UV radiation or excessive heat such as fireplaces, or behind cooktops, stoves, or rear venting ovens, using HanStone Quartz in such a way will void the warranty.

HANSTONE PRODUCT HANDLING AND SAFETY STATEMENT FOR STONE PROFESSIONALS WITH REGARDS TO CRYSTALLINE SILICA

According to the Occupational Safety and Health Administration (OSHA), “Crystalline silica is a common mineral found in the earth’s crust. Materials like sand, stone, concrete, and mortar contain crystalline silica. It is also used to make products such as glass, pottery, ceramics, bricks, and artificial stone. Respirable crystalline silica – very small particles at least 100 times smaller than ordinary sand you might find on beaches and playgrounds – is created when cutting, sawing, grinding, drilling, and crushing stone, rock, concrete, brick, block, and mortar. Activities such as abrasive blasting with sand; sawing brick or concrete; sanding or drilling into concrete walls; grinding mortar; manufacturing brick, concrete blocks, stone countertops, or ceramic products; and cutting or crushing stone result in worker exposures to respirable crystalline silica dust. Industrial sand used in certain operations, such as foundry work and hydraulic fracturing (fracking), is also a source of respirable crystalline silica exposure. Workers who inhale these very small crystalline silica particles are at increased risk of developing serious silica-related diseases, including:

- Silicosis, an incurable lung disease that can lead to disability and death.
- Lung cancer.
- Chronic obstructive pulmonary disease (COPD).
- Kidney disease.

To protect workers exposed to respirable crystalline silica, OSHA has issued two respirable crystalline silica standards: one for construction, and the other for general industry and maritime.”These standards can be found on www.osha.gov in the Small Entity Compliance Guides.

According to the Canadian Centre for Occupational Health and Safety, it is the employer’s responsibility to provide workers with necessary education and supervision; develop a written exposure control plan; post warning in the work area; provide adequate washing facilities; develop safe work procedures for dealing with silica dust; and monitor worker exposure to silica. When required, workers must wear properly fitted, tested, and certified personal protective equipment (PPE)—respirators, eye wear, and protective clothing.”Employers and workers alike need to be aware of the hazards of the work activity and the job site. Know the operations and job tasks that generate crystalline silica dust, understand the related health hazards, and protect against exposure to this hazardous dust.”

HANSTONE PRODUCT HANDLING AND SAFETY STATEMENT FOR STONE PROFESSIONALS WITH REGARDS TO CRYSTALLINE SILICA

NOTICE FOR STONE PROFESSIONALS:

HanStone is classified as non-hazardous under the GHS (Globally Harmonized System) of Classification and Labelling of Chemicals. In its solid form, as a beautifully installed countertop, or other surface application, HanStone poses no health hazard. HanStone is composed of various premium minerals including crystalline silica—on average, the content is less than 88%. Crystalline Silica is a common mineral found in the earth's crust and in everyday materials such as sand, stone, concrete, and mortar. Please note: Any cutting, grinding, polishing, drilling or other fabrication work performed on this product may generate crystalline silica dust which can become airborne. Prolonged exposure and inhalation of crystalline silica dust may cause respiratory problems, including silicosis. DO NOT dry-cut HanStone under any circumstances. You must take all necessary precautions, including, not limited to, a proper water delivery system which is required at all times. ALWAYS wear a proper certified mask for respiratory protection. Refer to Product Safety Data Sheet in the appendix for additional information. It is the stone professional's sole responsibility to follow the guidelines provided by OSHA or CCOHS to develop, implement and enforce safe work procedures for dealing with silica dust. Hyundai L&C Canada Inc. operating as HanStone Canada and its affiliates are NOT liable for any individual's failure to follow these safety guidelines.

SAFETY DATA SHEET

Section 1: Identification

Product Name:	HanStone® Quartz
SDS Revision Date:	July 2019
Product Identifier:	Engineered solid stone surfaces, Quartz surfaces
Product Use:	Engineered stone surfaces for use as countertops, vanities, and other surfaces throughout residential and commercial interiors
Company:	Hyundai L&C Canada 2860 Innovation Drive London ON N6M 0C5 Canada
Emergency Phone Number:	1-519-617-7101

Section 2: Hazard(s) Identification

For Shipping Finished Product

GHS Classification:

Not applicable. Material is classified as non-hazardous

HanStone in its solid form poses no health hazard. If dust is created during fabrication or demolition respirable crystalline silica dust if allowed to become airborne increasing the risk of inhalation can occur; the following applies:

GHS Classification:

H350 H372 Carcinogenicity – Category 1A
H335 Category 3 (Respiratory tract irritation)

Signal Word: DANGER!



Hazard Statement:

H350 May cause CANCER
H372 Causes damage to organs through prolonged or repeated exposure
H335 May cause respiratory irritation

Precautionary Statements

Prevention:

P201 Obtain special instructions use
P202 Do not handle until all safety precautions have been read and understood
P260 Do not breathe dust
P264 Wash face and hands thoroughly after handling
P270 Do not eat, drink or smoke when using this product
P280 Wear protective gloves/protective clothing/eye protection
P284 Wear respirator protection P3 for particulates
Use personal protective equipment as required (respirator, cut resistant gloves, protective clothing)

Response:

SAFETY DATA SHEET



P308 IF exposed or concerned:
P313 Get medical advice/attention if you feel unwell

Disposal:

P501 Dispose of waste material as per local regulations.

Section 3: Composition/Information on Ingredients

Components	CAS Number	Proportion %
Crystalline Silica/Quartz	14808-60-7	≤86
Cristobalite	1446-46-1	<50
Glass & Mirror	NA	<24
Polyester Resin	Mixture	7-14
Other Material	NA	<4
Titanium Dioxide	13463-67-7	<1.5
Inorganic Pigment Mixture	NA	<1

Percentages vary based on slab design.

Section 4: First-Aid Measures

Inhalation: Remove to fresh air and keep at rest in a position comfortable for breathing. If difficulty in breathing persists get medical attention. If breathing is difficult, provide oxygen.

Skin Contact:

Wash with plenty of soap and water. If skin irritation occurs get medical advice/attention. Broken edges of finished product may be sharp causing laceration to skin, if needed seek medical attention.

Eye Contact:

Immediately rinse with water for a prolonged period while holding the eyelids wide open. Remove contact lenses, if present and able. Seek medical attention if material is embedded in eye. If eye irritation persists get medical advice and attention.

Ingestion:

Not applicable under normal handling conditions. If large amounts of dusts are ingested rinse mouth. Do not induce vomiting. Seek medical attention.

Most important symptoms and effects (acute or delayed/chronic)

Acute:

Respiratory tract: sneezing, coughing, burning sensation of throat with constricting sensation of the larynx and difficulty in breathing.

Skin: Dust can cause mechanical abrasion, redness, rash like appearance, discomfort. Sharp edges can cut skin

Eyes: redness, discomfort, pain.

Ingestion: Abdominal pain.

Delayed/Chronic:

Repeat or prolonged exposure may cause cancer/silicosis. Symptoms include: coughing, difficulty breathing, wheezing and progressive lung function impairment.

Indication of any immediate medical attention and special treatment needed

No additional information is available

Section 5: Fire-Fighting Measures

Extinguishing Media

Suitable extinguishing media: Water, Dry Chemical, Co2, Foam

Unsuitable extinguishing media: None known

Special hazards arising from the substance or mixture

Fire hazard: Not flammable. Can be combustible with difficulty. When heated to decomposition, may release various hydrocarbons, carbon dioxide, carbon monoxide and water. Metal oxides and mineral fumes could also be released.

Explosion hazard: Not applicable

Reactivity: Hazardous reactions will not occur under normal conditions

Advice for firefighters

Precautionary measures fire: Fight fire with normal precautions from a reasonable distance

Firefighting instructions: Ensure personnel are keep a distance and upwind of fire.

Protection during firefighting: Use self-contained breathing apparatus and individual fire protective equipment.

Section 6: Accidental Release Measures

Use of personal precautions

Wear appropriate respirator protection and safety glasses where a risk of exposure to dust is present. Wear cut resistant gloves where sharp edges are present.

Environmental Precautions

If large quantities enter waterways, contact, Federal, State/Provincial, Local Environmental Regulators.

Methods for containment/cleaning up

Avoid generating dust. Recover material for reuse and reclamation when possible. Use of HEPA vacuum systems or shoveled/swept after light wetting down to avoid generating airborne particles. **DO NOT DRY SWEEP.**

Section 7: Handling and Storage

Precautions for Safe Handling

Avoid breathing dust. When fabricating and installing product, wet production methods should be used to minimize dust. Use adequate ventilation to minimize dust. Use vacuum cleaning equipment and wet methods to minimize generation of dust. Wash hands thoroughly with soap and water after handling prior to eating, drinking or smoking.

Precautions for Safe Storage

Secure properly when placing slabs on rack or A-frame. Ensure rack or A-frame is rated to handle the weight of the load. Product is heavy and breakable, secure slabs with care when storing or transporting to prevent injury and damage. Do not store slabs outside or expose to excess sun and rain.

Section 8: Exposure Controls/Personal Protection

Exposure limits

Component (Respirable)	ACGIH American Conference of Governmental	NIOSH National Institute for Occupational Safety and Health	OSHA-PELS OSHA PEL

SAFETY DATA SHEET



	Industrial Hygienists - ACGIH TLV (2019)		
Silica, Crystalline: Quartz	0.025 mg/m ³ TWA	0.05 mg/m ³ TWA	0.05 mg/m ³ TWA
Silica, Crystalline Cristobalite	0.025 mg/m ³ TWA	0.05 mg/m ³ TWA	0.05 mg/m ³ TWA

Abbreviations

TWA = Time Weighted Average. TLV: Threshold Limit Values 8 hr time weighted average. PEL: Permissible Exposure Limit 8 hr time weighted average. REL Recommended Exposure Limit 10 hr time weighted average. These limits may change from time to time, follow all local safety laws.

Consult with trained occupational health and safety professionals to monitor and conduct air sampling in the workplace to determine worker exposure levels and implement prevention and control methods.

Engineering Controls

Ventilation must be adequate to maintain the ambient workplace atmosphere to that below the exposure limits listed above.

Use at the source dust extraction equipment.

Use machinery and tools that use the wet method to minimize airborne dust.

Use vacuum cleaning equipment, or wetting material before a gentle sweeping to minimize generation of dust.

Do not use compressed air to remove dust.

Eyewash facilities should be readily available.

Personal Protective Equipment:

Eye / Face Protection:

Use safety glasses with side shields or safety goggles.

When cutting, drilling, grinding or polishing wear face and neck protection.

Skin / Body Protection:

Cover skin to minimize risk of mechanical irritation.

Wear gloves when handling dry dust.

Wear cut resistant gloves when exposed to sharp edges.

Wear steel toed safety footwear.

Respiratory Protection:

Use NIOSH approved filtering face piece respirator for protection against dusts or higher level of respiratory protection as indicated where there is potential to exceed the exposure limits. Follow the requirements based on your jurisdiction: The Canadian Safety Association CSA Standard Selection, Use and Care of Respirators Z94.4-11 or the OSHA's Respiratory Protection Standard, 29CFR1910.134 and to the NIOSH Respirator Selection Logic 2004 DHHS (NIOSH) for appropriate selection of respirators. Employees must be trained and qualified to use a respirator.

Section 9: Physical and Chemical Properties

Appearance:	Multi-coloured engineered quartz solid stone
Odour:	Odourless
pH:	NA
Melting Point/Freezing Point:	NA
Boiling Point:	NA

SAFETY DATA SHEET

Flash Point:	490°C
Flammability:	NA
Evaporation Rate:	NA
Density:	2.38 – 2.40 g/cm ³
Solubility in Water:	Insoluble in water
Moisture Absorption:	0.03%
Upper/Lower Flammability Limit:	None
Viscosity:	None, solid

Section 10: Stability and Reactivity

Reactivity:

This product is stable under most conditions.

Chemical Stability:

Avoid contact with hydrofluoric acids

Physical Stability:

Strong impact may cause material to break.

Hazardous Decomposition:

Thermal decomposition can release various polymer, pigments, hydrocarbons, carbon dioxide, carbon monoxide and water. Fumes of metal oxides and mica particles may also be released.

Hazardous Polymerization:

None

Section 11: Toxicological Information

No toxicological data is available for this product in solid form. No adverse health effects expected if the product is handled in accordance with this Safety Data Sheet. The following information is based on respirable crystalline silica/quartz dust released during operations involved in the fabrication process, such as: grinding, drilling, cutting and polishing operations. Symptoms or effects that may arise if the product is mishandled and overexposure occurs are:

Warning for inhalation exposure only:

Crystalline silica (respirable size) has been classified by the IARC as Group 1 Carcinogen to humans.

Acute Effects

Crystalline Silica / Quartz :

Inhalation (Human) LC Lo: 0.3mg/m³/10 Y

Inhalation (Human) TC Lo: 16mppcf/8H/17.9 Y

Intermittent: focal fibrosis, pneumoconiosis, cough, dyspnoea

Inhalation (rat) TC Lo:

5.0 mg/m³/6 H/71W

Intermittent – Liver Tumours

Oral LD₅₀ Rat: 500 mg/kg

Section 12: Ecological Information (non-mandatory)

Environmental Fate: No information available

Environmental Toxicity: No information available

Section 13: Disposal Considerations (non-mandatory)

This section provides guidance on proper disposal practices, recycling or reclamation of the chemical(s) or its container, and safe handling practices. To minimize exposure, this section should also refer the reader to Section 8 (Exposure Controls/Personal Protection) of the SDS. The information may include:

- Description of appropriate disposal containers to use.
- Recommendations of appropriate disposal methods to employ.
- Description of the physical and chemical properties that may affect disposal activities.
- Language discouraging sewage disposal.
- Any special precautions for landfills or incineration activities

Section 14: Transport Information (non-mandatory)

This section provides guidance on classification information for shipping and transporting of hazardous chemical(s) by road, air, rail, or sea. The information may include:

- UN number NOT REGULATED
- UN proper shipping name NOT REGULATED
- Transport hazard class(es) NOT REGULATED
- Packing group number, if applicable, based on the degree of hazard NOT REGULATED

Section 15: Regulatory Information (non-mandatory)

This section identifies the safety, health, and environmental regulations specific for the product that is not indicated anywhere else on the SDS. The information may include:

- Any national and/or regional regulatory information of the chemical or mixtures (including any OSHA, Department of Transportation, Environmental Protection Agency, or Consumer Product Safety Commission regulations)

Section 16: Other Information

This section indicates when the SDS was prepared or when the last known revision was made. The SDS may also state where the changes have been made to the previous version. You may wish to contact the supplier for an explanation of the changes. Other useful information also may be included here.

MATERIAL INSPECTION CHECKLIST

Upon receiving HanStone Quartz slabs from your distributor, a visual inspection is mandatory before cutting, fabricating, altering, or before permanent installation. Please refer to the "Inspection Period" in your General Terms and Conditions Agreement attached to your order confirmation.

PLEASE REMOVE ALL FILM FROM THE SLABS AND INSPECT THE SURFACE AREA FOR DEFECTS AND/OR COLOUR VARIATION.

Some things to look for are:

- Pattern irregularities
- Blotches/resin blotches/pooling
- Colour variance
- Check lot numbers between multiple slabs (found on label stickers and printed on the back of each slab)
- Cracks/chips/stress marks
- Broken slabs
- Scratches/streaks/swirl marks/dull spots in finish
- Pits or voids on the surface side
- Spots/irregularities
- Foreign material
- Warpage
- Inconsistent finish
- Thickness +/-

NOTE: After checking and performing a quality control inspection of the slab, if you find any Product Non-Conformities (PNC), which will greatly increase your fabrication time and cannot be resolved quickly, please contact your local HanStone Quartz distributor for further instructions.

Hyundai L&C will not be held responsible for any labor charges incurred for fabrication of such defective materials or any incidental loss or damages as a result of mishandling. Any PNC issues should be reported to a local HanStone Quartz supplier prior to cutting, fabricating and/or installation. Failure to thoroughly inspect slabs before cutting or modifying in any way will void any opportunity at exchange or warranty claim.

DISCLAIMER:

SURFACE DEVIATIONS

Some HanStone Quartz slabs such as Rocky Shores, Kindred, and Blackburn etc. use large grain quartz aggregate in their production. Because of this, surface deviations are more noticeable to the touch and appearance. These inclusions are a normal, inherent trait expected of this quartz product and do not affect product performance.

COLOUR VARIATION

HanStone is made from natural quartz. Variation in colour, shade and pattern are an inherent and natural characteristic of this product. A sample piece is a general representation based on a small, select cut of a full slab and does not indicate all design characteristics of the full slab or the final installed product. Colour blotches are intended and inherent part of design in many colours to enhance the overall natural aesthetics. HanStone Quartz is not a seamless product. Anywhere there are seams, they will be visible. Colour, shade, and pattern may vary in areas with seam transitions. This is not considered a manufacturing defect.

MATTE FINISHES- LEATHERED AND RIVERWASHED

HanStone's Leathered and Riverwashed finishes will naturally show more grease and oil marks than their polished cousins. Because of this, extra care must be taken during fabrication and installation to avoid contacting the surface with wax, silicone, epoxy, or other oils and adhesives. When installing the sink, it is recommended to tape off the edge first and remove after the sink has been set and the silicone has been wiped clean. This will leave a clean bead of silicone sealant along the rim of the sink. This same "taping off" method may be used during the seaming process. Do not leave dirty rags on the surface as they may leave adhesive stains that are hard to remove from the matte finished material.

HYUNDAI L&C WILL NOT BE HELD RESPONSIBLE FOR ANY LABOR CHARGES INCURRED FOR FABRICATION OF SUCH DEFECTIVE MATERIALS OR ANY INCIDENTAL LOSS OR DAMAGES AS A RESULT OF MISHANDLING. ANY PNC ISSUES SHOULD BE REPORTED TO A LOCAL HANSTONE QUARTZ SUPPLIER PRIOR TO CUTTING, FABRICATING AND/OR INSTALLATION. FAILURE TO THOROUGHLY INSPECT SLABS BEFORE CUTTING OR MODIFYING IN ANY WAY WILL VOID ANY OPPORTUNITY AT EXCHANGE OR WARRANTY CLAIM.

SLAB IDENTIFICATION STICKER

Each HanStone slab has an identification label affixed to either end. If this label is removed, the slab lot number can be found printed on the back of each slab. Before starting, always ensure multiple slabs are from the same lot number. This will help to minimize the chance of colour variation from slab-to-slab. If seaming 2 pieces together, it is strongly recommended to use pieces from the same lot number as close to consecutively as possible.

HanStone also recommends always doing a visual inspection of the areas that are being seamed together for colour/pattern variation even if the slabs are from the same lot. If colour/pattern does not meet the fabricators/end user's satisfaction, slabs can be exchanged, as long as they have not been cut or modified in any way.

HanStone Quartz slab identification stickers contain useful information related to factory production, slab colour, finish, thickness, size, and slab grade. All of this info can be beneficial for all of the processes related to quartz manufacturing, transportation, fabrication and installation.

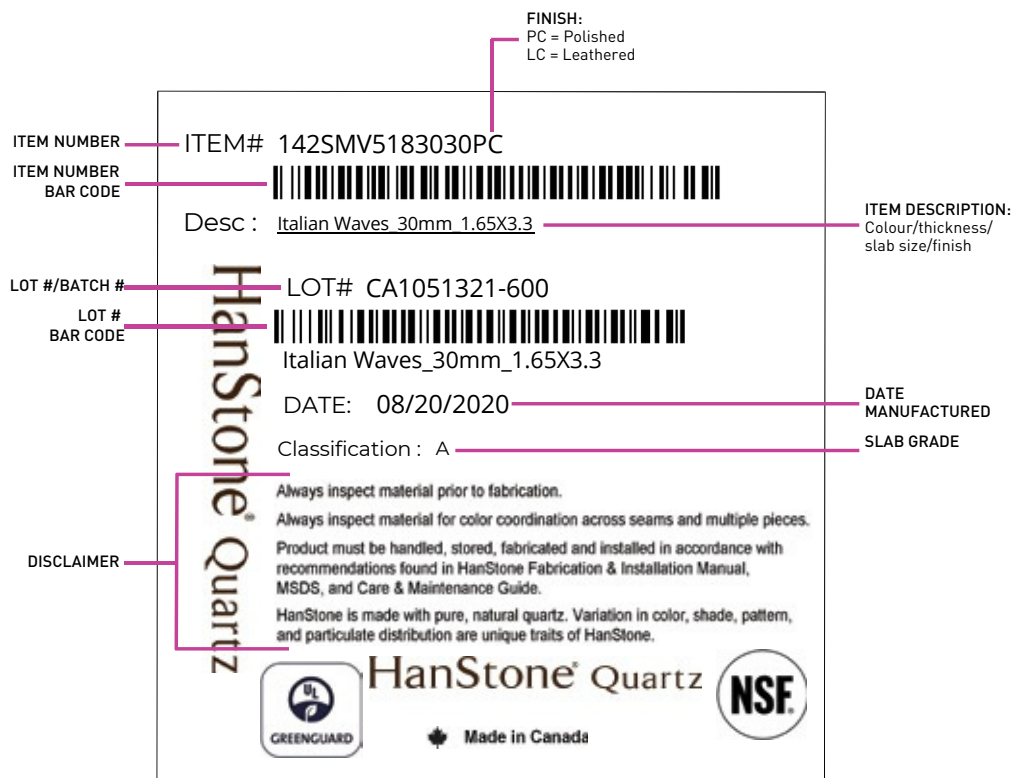

FABRICATION AND SAFETY EQUIPMENT

It is imperative that the health and safety of all workers should be of the utmost importance to all companies, large or small. Using the right tools for any job is one of the most important aspects of working safety.

Here are some examples of tools required to properly fabricate HanStone Quartz slabs.

Shop Machinery

- Bridge saw
- CNC machine
- Water Jet
- Line polisher (single or multi-head)
- Water treatment equipment
- Air compressor, hoses and accessories

Handling and Storage Equipment

- Overhead gantry
- Jib boom
- Forklift
- Vacuum lifter/slab clamp
- A-frames/storage racks
- A-frame carts
- Slab dolly
- Vacuum cups
- Fabrication tables

FABRICATION AND SAFETY EQUIPMENT

Hand Tools

- Water fed air polisher with variable speed preferred
- Wet profiling machine (edge router)
- C-clamps for lamination
- Miter clamps
- Angle grinders with variable speed preferred
- Diamond blades for use with engineered stone
- Diamond cups wheels
- Contour blades for cutting radius
- Zero tolerance drums
- Core bits
- Grinding stones
- Straight edges
- Flexible and rigid backer discs for polishing pads
- Polishing pads (50, 100, 200, 400, 600, 800, 1000, 1500, 3000) Felt pad and polishing powder
- Single edge razor blades
- Putty knives

Installation Tools

- Tape measure
- Carpenters square, combination square, bevel square, angle finder and compass
- Drill
- Jigsaw, oscillating saw, circular saw
- Variable speed angle grinder
- Diamond blades
- Core bits in various sizes
- Polishing pads and Velcro backers
- Diamond cup wheels
- Zero tolerance drums
- C-clamps, Bar clamps
- Saw Horses for on-site cutting
- Extension cords
- Shop Vac
- Floor coverings/Drop cloths

FABRICATION AND SAFETY EQUIPMENT

Installation Tools (Cont'd)

- 4/6/8 ft levels
- Torpedo level
- Utility knife and blades
- China markers, carpenters' pencils
- Painters tape
- Pine or composite shims (composite is recommended as they do not get affected by moisture)
- 6' pry bars
- Suction cups
- Slab clamps
- Sink hole saver
- Pro cart slab dolly
- Gorilla grips or other seam setting devices
- 90-degree seam setting device for waterfall gables
- Rags or paper towels
- Solvents for clean-up- Methyl Hydrate/Methanol or Denatured Alcohol (Never use **Acetone**)
- Caulking guns
- Adhesive gun for integra glue (if used) and mixing tips
- Single edge razor blades
- Propane torch and tip
- Putty knives
- C-clamps, Bar clamps

Adhesives

- 100% silicone
- DAP caulking
- Flow and/or knife grade epoxy
- Polyester
- Methacrylate ester
- Penetrating acrylic
- Appropriate pigments and hardeners

FABRICATION AND SAFETY EQUIPMENT

Safety Equipment

- First Aid kit
- Safety glasses
- Dust masks-ALWAYS wear correct fitting, tested, and certified dust masks. Proper OSHA approved respiratory protection is required at all times.
- Protective non slip gloves Nitrile gloves
- Waterproof aprons
- Ear plugs
- Eyewash station
- Proper safety footwear
- Hard hats when needed
- Reflective vest when needed

Following these recommended guidelines should ensure trouble free fabrication and installation of HanStone Quartz.

Note that the material contained in this bulletin is, for the most part, general and non- specific. More detailed information on tooling, RPM's, feed rates, etc. can be obtained from your specific equipment manufacturers or tooling vendors.

Also note that there are a large number of variables in the fabrication process that can affect the final outcome and potentially result in damage to the material. Some of these variables are; slab handling methods, level cutting bed or table, type and condition of saw blade, cutting feed rate, pressure (waterjet) spindle speed (RPM's), volume and placement of coolant (water), and geometry of cutting. Any of these variables can have an impact on accurately cutting HanStone quartz slabs and eliminating damage.

MATERIAL AND EQUIPMENT CHECK

- Acclimate slabs to shop temperature before beginning. Frozen slabs have a higher risk of cracking during cutting.
- **Inspect: Always remove film from slabs and fully inspect for any defects before starting any type of fabrication. Do not cut with the film on.**
- Fissure and Crack Check: When fabricators receive slabs, they should check them for fissures or cracks. Hosing the slab down with water helps you see any cracks or fissures you may not have noticed beforehand. If cracks or fissures are found, the fabricator should refrain from cutting.
- NEVER DRY CUT. Always cut, drill, and polish using adequate amounts of water. Failure to do so may result in over heating of the slab and cutting blade/bit, and potential cracking issues and or discolouration. This also helps to minimize airborne silica dust and ensure the safety of all stone workers and associated employees.
- Blades: Use the right blade for the saw. Check with the saws manufacturer to make sure you are using the best blade for the application. GranQuartz reps are knowledgeable when it comes to selecting the right blade for your saw and material. Saw blades are not universal.
- Regularly inspect your blade for true (square) and excessive wear or missing segments and replace when necessary.
- Maintain a level cutting bed. Depending on volume, resurface saw tables / change waterjet slats every 6 to 8 weeks. Ensure that the cutting table is perfectly level and flat to reduce the risk of cracking during the cutting process. The cutting table must also be solid without any gaps/open space.
- Never use materials such as polystyrene foam insulation or cement board as a cutting bed. These materials are too soft and compressive and tend to deteriorate fast creating weak spots and out of level conditions.

FABRICATION GUIDELINES

- Always start by taking a cut off one length-side and one width-side of the slab. This will help to release any tension in the slab.
- Amp Draw: Pay close attention to amp draw and cut speed. If your amp draw begins to rise you may need to dress or replace the blade. You may also be cutting too fast.
- Don't Plunge cut! Avoid plunge cutting whenever possible. ALWAYS cut from the OUTSIDE edge and into the slab: Start the cut from the outside of the material and cut inwards. Lift your saw out when you need to stop.
- All inside corners must have a minimum 3/8" (10mm) radius. Avoid fractures by predrilling holes on the inside corners that are to be radiused. i.e., L/U shapes, sink, cooktop, other cutouts.
- Whenever possible, cut from the outside of the slab toward the centre. If you must plunge cut from the centre, prior to cutting with the saw, you must drill 1" relief holes at all corners and/or termination points. Avoid interrupting.

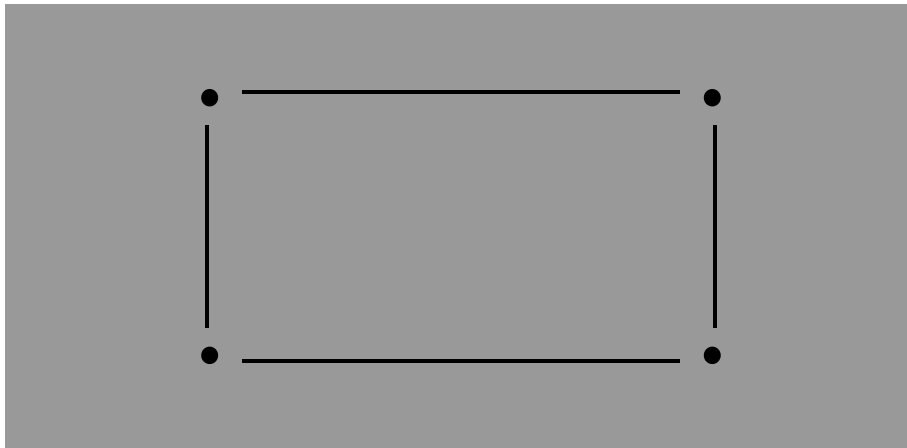

Figure 1: All 4 corners of a cutout must be cored prior to making plunge cuts. This also applies to L or U-shaped pieces.

- When cutting L and U shapes, all intersecting inside corners must have 1" relief holes drilled first - then, starting from the outside of the slab, cut the shortest length first towards the relief hole followed by the longest cut.

FABRICATION GUIDELINES

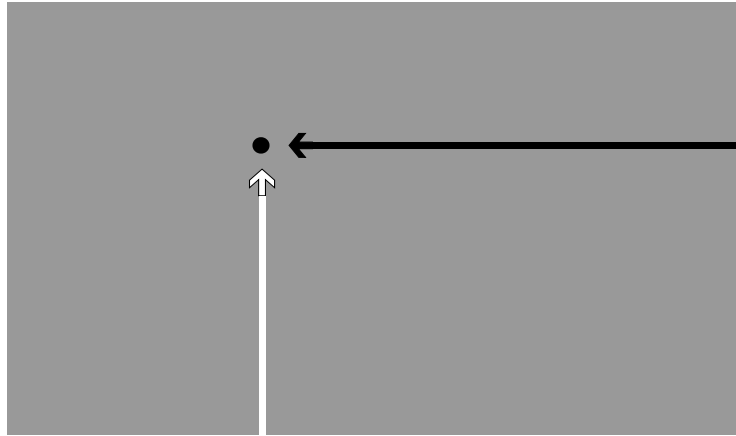

Figure 2: In this example, after the relief hole has been made the shorter WHITE cut must be made first, followed by the longer BLACK cut.

- Use Shims. Insert shims behind the blade as you are cutting. This will help keep the material from closing up and pinching the blade. You can also use shims to support the slab in any areas where it might have a slight warp to it. This will prevent it from settling and possibly cracking as it is cut.
- Warping: If the slab is warped, it will begin to level out unevenly as it is cut. This can result in either a blowout or a pinched blade.
- Do not ever alter the surface of HanStone Quartz slabs. This includes re-polishing, buffing, honing, sealing, or modifying in anyway.

CUTTING SPEED

The cutting speed is divided into two distinct but interrelated factors;

- Blade or spindle rotation (RPM's)
- Sawing feed rate

The cutting speed is dependent on a number of variables which includes the type of equipment being used, type of blade, bond hardness, diamond grit size, wear on the blade, just to name a few. Always comply with equipment manufacturer's recommendations and/or tooling vendor's advice. Keeping the above statement in mind, here are a couple of general guidelines regarding cutting speed:

FABRICATION RECOMMENDATIONS

(This speed applied for Genya cutting machine from Breton and knife fi500, thickness 4mm from ADI brand)

2cm Thickness slab:

- Feed rate: 2.8 meters/minute (or less than)
- Spindle rotation speed 1850 rpm
- The depth of the knife penetrates cutting table 1mm
- Safe height when exiting the knife 4cm
- knife lifting speed 3.5 meters/minute
- knife lowering speed 0.42 meters/minute

3cm Thickness slab:

- Feed rate: 2.1 meters/minute (or less than)
- Spindle rotation speed 1850 rpm
- The depth of the knife penetrates cutting table 1mm
- Safe height when exiting the knife 5cm
- knife lifting speed 2.6 meters/minute
- knife lowering speed 0.32 meters/minute

*Colors that are produced from Cristobalite such as: Tranquility, Chantilly, Royale Blanc, our Calacatta colours, etc. require more care and should be cut more slowly and carefully.

CUTTING SPEED

Cooling with Water ' Supplying an adequate volume of water at the sawing interface is a requirement for error free cutting of HanStone. Cutting with water prolongs the diamond blade life, reduces heat build-up, and helps reduce cracks that can be caused by overheating. Water must be supplied in the proper location or it will not cool the blade or the material properly. Water should always be focused at the point of contact between blade and material, and in the same direction as rotation of the blade. The amount of water used should be increased from the amount used in sawing granite or marble. If sparks are visible in the cutting process, or discolouration is found within the cuts, the water volume is insufficient or not reaching the blade / material interface.

To Avoid Excessive Chipping or Cracking

- Use a finer diamond grit blade.
- Reduce speed, both RPM & feed rate.
- Check blade for true (square) and excessive wear or missing segments.
- Check to see if enough coolant is reaching the blade / material interface.
- Always start by cutting off one length-side and one width-side of the slab. This will help to release any tension in the slab.
- Do not plunge cut. Whenever possible, cut from the outside edge into the slab. Lift your saw out when you need to stop.
- If plunge cutting is necessary, holes should be cored at all corners beforehand to avoid cross cutting and cracking.
- Relief cuts should be made at areas that will have a corner or curve to avoid blow outs.
- All inside corners must have a minimum 3/8" (10mm) radius.

CUTTING SPEED

CNC Cutting: Best Practice

When using a CNC to cut and edge HanStone pieces, you will be using either a special tool fitted with a diamond saw and sawblade, or a diamond impregnated finger bit. If using the saw and sawblade tool, please refer to the previous section on 'Sawing Best Practices'.

When using a diamond finger bit, select a bit that features soft bond segments or one that is specifically recommended for quartz surfaces. Finger bits are generally 7/8' to 1' in diameter. Because of the large amount of material removed with a 1' bit, feed rates will be much slower than using a saw. When using a CNC there are many variables that can affect the performance of the equipment. Keeping in mind that you should always comply with equipment manufacturer's recommendations and/or tooling vendor's advice, here are some general cutting guidelines using diamond finger bits on a CNC;

- **Spindle RPM's should be between 4,000 – 8,000.**
- **Feed rate should be 8" to 16" / minute.**

Cooling with Water ' Supplying an adequate volume of water at the cutting interface is a requirement for error free cutting of HanStone. Cutting with water prolongs the diamond tooling life, reduces heat build-up, and helps reduce cracks that can be caused by overheating. Water must be supplied in the proper location or it will not cool the finger bit or the HanStone properly. Water should always be focused at the point of contact between finger bit and the material, and in the same direction as rotation of the bit. The amount of water used should be increased from the amount used in cutting granite or marble. If sparks are visible in the cutting process, the water volume is insufficient or not reaching the tool/ material interface.

To Avoid Excessive Chipping or Cracking

- Use a finer diamond grit blade.
- Reduce speed, both RPM & feed rate.
- Check blade for true (square) and excessive wear or missing segments.
- Check to see if enough coolant is reaching the blade / material interface.
- Always start by cutting off one length-side and one width-side of the slab. This will help to release any tension in the slab.
- Do not plunge cut. Whenever possible, cut from the outside edge into the slab. Lift your saw out when you need to stop.
- If plunge cutting is necessary, holes should be cored at all corners beforehand to avoid cross cutting and cracking.
- Relief cuts should be made at areas that will have a corner or curve to avoid blow outs.
- All inside corners must have a minimum 3/8" (10mm) radius.

CUTTING SPEED

Waterjet: Best Practice

Waterjet cutting is accomplished using a high velocity stream of water and abrasive to cut HanStone slabs. Water pumped at 40,000 to 60,000 psi accelerates through a sapphire, or ruby orifice. The stream mixes with abrasive and air as it accelerates through the nozzle, exiting as an abrasive stream with a cutting diameter of 0.020' to 0.060'. The combination of high velocity water and abrasive particles impact on the material face to perform the actual cutting. Quartz material is removed as microchips, with the resulting kerf often serrated at the bottom.

The stream which produces the cut will generally carry 0.5 to 1.5 pounds per minute of abrasive. The quantity of abrasive is dependent on the orifice size which in turn, produces the cutting stream size. This is chosen based on the material being cut. The most cost effective and commonly used abrasive is garnet.

The cutting speed is variable with the trade-off being the quality of the cut. Most manufacturers use a scale of 5 levels of quality in cutting. At faster speeds the cut becomes visibly serrated and irregular at the bottom of the cut. This corresponds with the lowest level quality of cut or what is referred to as a separation cut ' Q1 (see below).

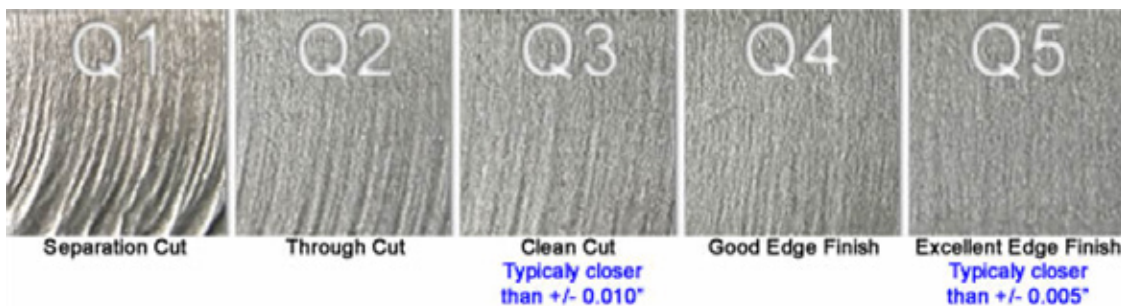

HanStone does not recommend Q1 or separation cut quality, as this could lead to material breakage during cutting. There are a great number of variables in the use of waterjet technology that can affect cutting speed. Some of these include the type of equipment being used, pump size, horsepower, pressure, abrasive volume, material thickness, geometry of cut, etc. In addition, the software that controls the cutting nozzle also varies in levels of complexity, allowing the cutting speed to change due to the varying geometry of the cut. Due to this you will need to consult with your equipment manufacturer for recommended feed rates.

CUTTING SPEED

Waterjet: Best Practice (Cont'd)

To Avoid Excessive Chipping or Cracking

- Maintain the slats that form the cutting bed. Replace when worn.
- Reduce feed rate. Never use Q 1 (separation cut) quality.
- Check abrasive volume and increase if necessary.
- Reduce the distance from the nozzle to the HanStone slab.
- Upgrade software to the most current version.

Summary

1. There are many variables in the fabrication process; slab handling methods, condition of equipment, level cutting bed or table, vacuum pressure, type of saw blade, cutting feed rate, water pressure, spindle speed, condition of tooling, volume and placement of coolant, and variable geometry of cutting, just to name a few. If HanStone material is breaking during the fabrication process, all of these variables should be looked at and/or adjusted prior to assuming that the slab is defective.
2. Always inspect slab material for defects prior to cutting.
3. In general, HanStone Quartz Surface should be cut at a slower speed or feed rate than granite. Colours produced from Cristobalite require more care and slower cut speeds.
4. Always start by cutting off one length side and one width side of the slab. This will help to release any tension in the slab.
5. Whenever possible, cut from the outside of the slab toward the center. Avoid plunge cutting.
6. If plunge cutting is necessary, 1" relief holes should be cored at all corners beforehand to avoid cross cutting and cracking.
7. Relief cuts should be made at areas that will have a corner or curve to avoid blow outs.
8. Supply an adequate volume of water at the cutting interface. The amount of water used should be increased from the amount used in cutting granite or marble.
9. Use the correct equipment, blades, and tooling for cutting Quartz Surfacing.
10. Always comply with the equipment manufacturer's recommendations and/or tooling vendor's advice.

CORNERS

- Whenever possible, the surfaces of L or U-shaped kitchens can be fabricated from one single slab. In these instances, a minimum of $3/8'$ radius must be used for inside corners. A larger radius will produce a stronger corner.
- Whenever a true 90-degree corner is requested, a seam must be used. This can be achieved using a straight seam, or a euro seam with a $1\ 1/2''$ - $3''$ radius.
- Regardless of piece size and corner dimensions, ALL inside corners must have a $3/8''$ (10mm) or larger radius. This includes bump outs around stoves, posts, and cut outs for appliances and sinks.

INCORRECT

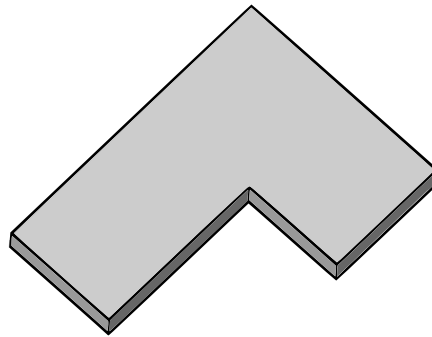

CORRECT

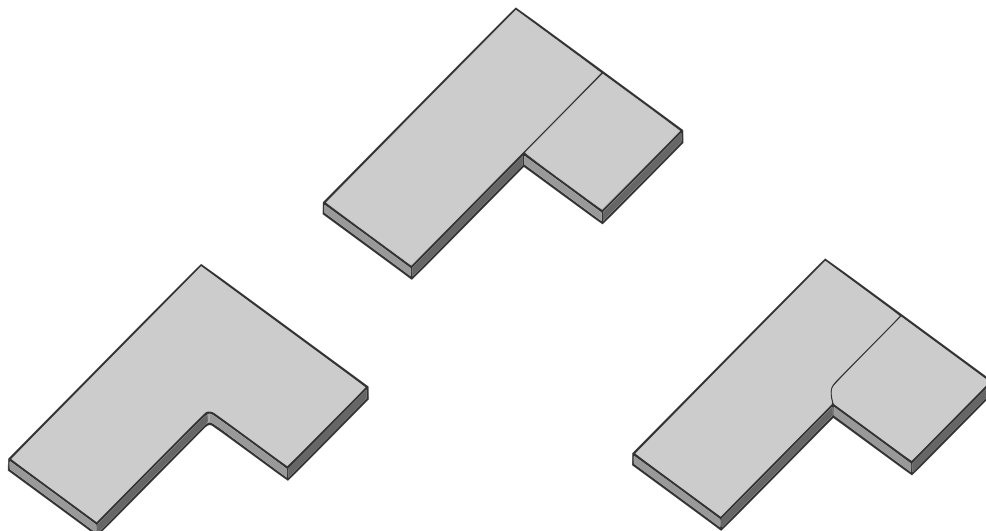

SEAMS

- Seams should be made flat and level using shims to adjust the material before applying adhesive.
- To allow maximum bonding strength, the bottom half of every seam edge should be roughened and biscuit cut, then cleaned before setting to allow the adhesive to properly bite.
- Never excessively bend the seaming area using clamps or a seam setting device. This will cause tension in the pieces that may lead to fracturing.
- A finished seam should be no more than 1/16' wide. This can be achieved using Gorilla Grips or similar seam setting tools.
- Do not surface polish seam areas to make them flat or level.
- Seams should always be fully supported on both sides, front-to-back, ideally on a double gable spanning from top to bottom.
- Seams should be avoided over the dishwasher or compactor. We do not recommend or honor warranty if a seam is placed over a dishwasher or a trash compactor.
- All seams should be at least 6' from all cutouts, such as sinks, cooktops, and other appliances. In addition, from an appearance point of view, try to position the seams so that they don't look out of place.
- Never run a seam through a cutout such as a sink or cooktop. This creates a weak spot.
- Seams should be a minimum of 18' from a finished end.

***HanStone Quartz is not a seamless product. Anywhere there are seams, they will be visible. Colour, shade, and pattern may vary in areas with seam transitions. This is not considered a manufacturing defect.**

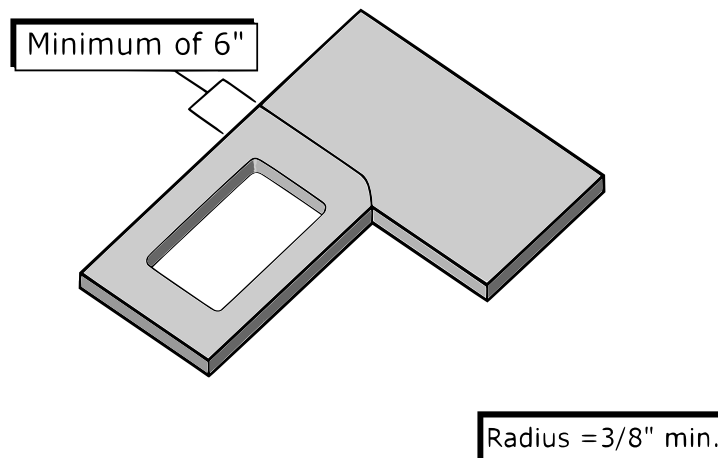

MITERED EDGES

- To maintain a tight fit and maximum strength, miters should always be cut at 45 degrees.
- A mitered joint should be clean, tight, and square.
- Always ensure the adhesive is fully distributed throughout the miter joint to avoid seam separation and chipping
- To avoid chipping, a minimum of 1/8 radius or bevel should be used to soften the mitered edge profile.
- Do not cut angles less than 45 degrees as this will promote damage such as chipping and cracking.
- Overcut miters filled with epoxy are prone to chipping and cracking and are not covered under warranty.
- **When installing mitered waterfall gables, ensure that the top is supported by the substrate and not the waterfall legs themselves. HanStone does not recommend supporting stone-with-stone and will not warranty any damage caused by improper installation.**

CORRECT

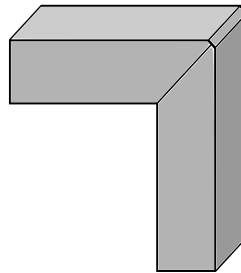

INCORRECT

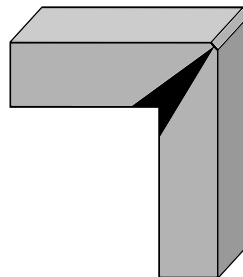

LAMINATION

- Lamination pieces should always span the full length of the top piece it is being adhered to. If this cannot be achieved, the joint in the lamination pieces must be 45 degrees to reduce any stress points.
- Outside corners can be cut at 45 degrees to create a cleaner look but a butt joint is also acceptable.
- It is important to use the same slab for lamination strips as the countertop surface to ensure proper colour match.
- Laminated edges should be polished to the same factory finish as the top surface of the stone.
- Prior to finish polishing, all excess adhesive must be removed from the edge profile, and the edges must be smooth and clean.
- Always polish using a water fed air polisher. Dry polishing will cause overheating leaving the edges prone to chipping and discolouration.
- A minimum of 1/8' radius or bevel is recommended on the top and bottom of edge profiles to prevent edge chipping.

INCORRECT

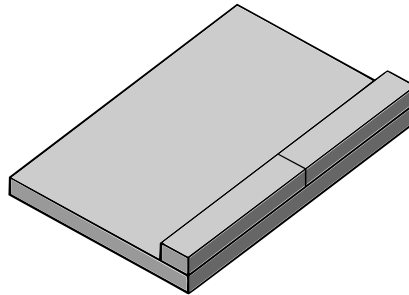

CORRECT

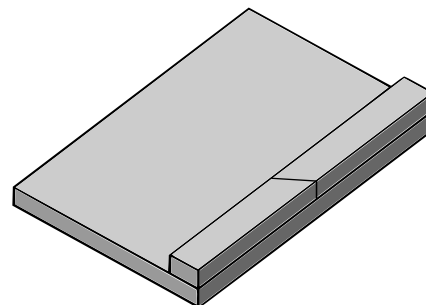
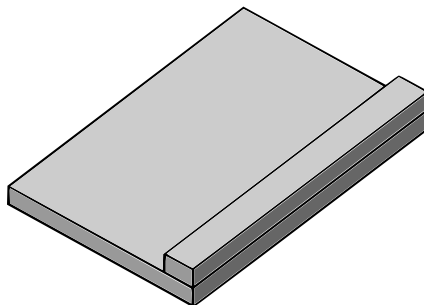

SEAMING ADHESIVES

- It is recommended that the manufactures instructions are followed for the proper use of all seaming and laminating adhesives.
- Proper mixing ratios must be followed along with minimum work temperatures to allow proper curing of adhesives.
- If using un-tinted 2-part adhesive, pigments must be added to closely match the stone colour to create an unnoticeable seam.
- Integra adhesives offers a wide range of pre-tinted adhesives that closely match HanStone Quartz.
- After the glue has cured, remove the seam setter and clamps. There will be a raised bead of glue along the seam (that squeezed out when the pieces were brought together). This will need to be removed with a razor blade. Hold the blade vertical and at a 45-degree angle to the seam. Scrape forward and backward on the bead until the glue is flush with the surface of the stone.
- Never soak the adhesive in solvent to soften it before removal.

SUPPORT

As with natural stone, HanStone Quartz is extremely heavy and needs to be supported properly. With both 2 and 3cm material, the tops can be set directly on top of the properly installed and leveled cabinets, as this provides the perimeter and cross support required. In certain markets, 2cm profiled edges are laminated to create a 4cm or thicker look. For these reasons, we require a built-up perimeter support or full sub top on our 2cm material that has been laminated.

Perimeter Support

- Recommended material ' 5/8" or 3/4" x 2"
 - Moisture resistant MDF
 - Moisture resistant plywood
 - Particleboard is not acceptable for this application
- Wood strips should be installed continuously along the front and back of the cabinets, and crosswise, (front to back) at the ends, and over every supporting gable.
- Tops should be fully supported with spans of no more than 36" between gables left to right and 24" front to back.
- Never shim the countertops in free space areas such as front or back stretchers, only shim load bearing structure such as gables.
- When a counter does need to be shimmed up, it is best to shim every 8" unless contacting the cabinet directly.
- Shim using pine or composite shims (composite is recommended as they do not get affected by moisture).
- Front-to-back support is also recommended under and along both sides of all seams.

SUPPORT

Overhang Support

Depending on the application, you might be required to provide overhang support for the countertop. These are some guidelines to follow when working with overhangs.

Requirements	2cm HanStone Quartz	3cm HanStone Quartz
Support not required	Overhangs under 12".	Overhangs under 15".
Full sub top with corbels	12"- 18" use full sub top along with corbels evenly spaced at 3' on center or less and extended more than half of the overhang.	15"- 20" use full sub top along with corbels evenly spaced at 3' on center or less and extended more than half of the overhang
Full sub top with legs or columns	Overhangs over 18" - use full sub top along with legs or columns connected at the top with rails of adequate size to provide perimeter support.	Overhangs over 20" use full sub top along with legs or columns connected at the top with rails of adequate size to provide perimeter support.
Raised bar mounted on the top of pony wall	Full sub top and bracket or corbel support at 3' (on center or less) is always required.	

SUPPORT

2/3 ON -1/3 OFF Rule

Always remember as a rule of thumb, with overhangs less than 12"/2cm or 15"/3cm, the overhang can still only be no more than 1/3 of the full length of the top provided there are not other means of support added.

For example: if the countertops are 30" wide, the allowable overhang can only be a maximum of 10" unless more support is added.

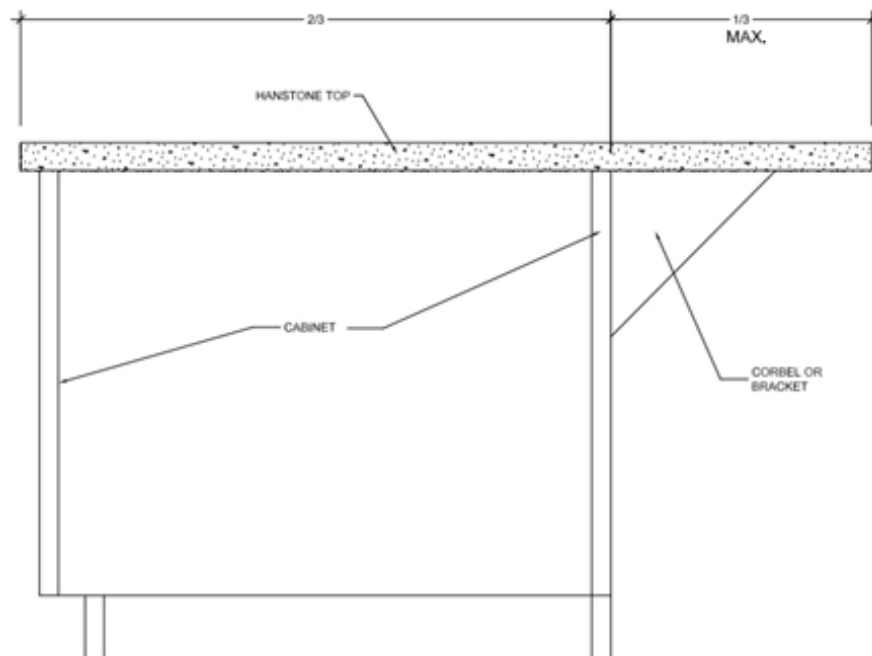

CUTOUTS

- When preparing a cutout, always use a core bit. Core out all 4 corners and then finish by cutting out the centers.
- It is mandatory to always leave a smooth radius within the corners of all cut outs (cook top, sink, or other) to avoid stress within each corner -3/8" (10mm) minimum radius.
- Do not cross cut or over cut these corners. Damaging the corners will cause stress points that may lead to fracturing.
- Remove all blade marks and leave cut smooth.
- Cutouts should not exceed 36". For use of equipment exceeding this size, provide separate countertop pieces on all sides of the appliance. For larger than normal cutouts such as these, silicone seams are recommended as this will allow for expansion and contraction. Proper support is required.

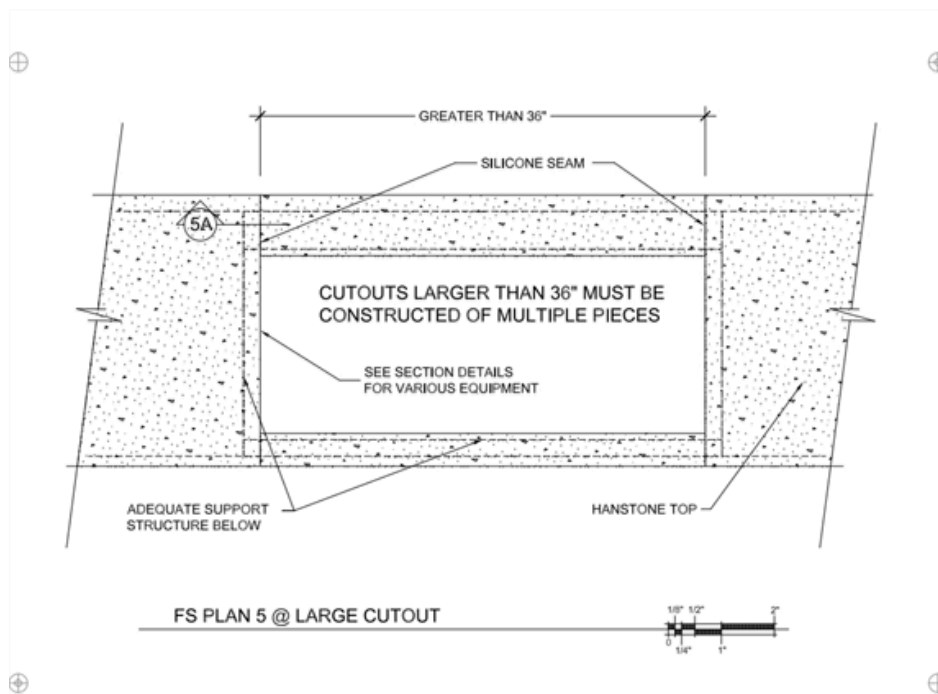

CUTOUTS



Figure 3: It is recommended to precut cooktop cut outs as shown here, then finish the cut on site. This will provide enough strength during transportation to avoid breakage.

APPLIANCES

- Always leave a minimum of 1/8' around all sides of appliances to allow for heat expansion.
- When installing cooktops, it is highly recommended to use aluminum reflective tape around all edges to protect the countertops from heat. Tape should not wrap the bottom edge of the counter, it should drop below the bottom edge.
- Double sided foam tape or silicone can be used to stick down cooktops.
- Under no circumstances should any mounting fasteners be drilled or screwed into HanStone Quartz surfaces.
- For dishwasher mounting, where no sub top is present, there are metal plates designed for this purpose which are glued to the underside of the countertop or screwed to either side of the cabinets.
- Hot pots or pans should never be placed directly on top of HanStone Quartz countertops. Trivets must always be used. Heated work top appliances such as crock pots and air fryers should also be placed on trivets as the prolonged heat exposure can cause seam separation, discolouration, and cracking.

COMMERCIAL APPLICATIONS

WHEN USING HANSTONE IN A COMMERCIAL KITCHEN OR FOOD SERVICE APPLICATION:

- Tops should be fully supported with spans of no more than 36" left to right, and 24" front to back.
- Cut-outs should not exceed 36". For use of equipment exceeding this size provide separate countertop pieces on all sides of the appliance or fixture.
- Silicone seams are recommended in commercial applications. This will allow for expansion and contraction – especially on large countertops.
- Use methods to ensure that heated appliances do not transfer the heat to the countertop. Numerous details are provided in this bulletin for reference.
- Do not attach any appliance, railing, sneeze guard, etc. directly to the countertop. Adequate support needs to be provided independent of the countertop. Drill through or cut out countertop as required and attach to the adequate support below.

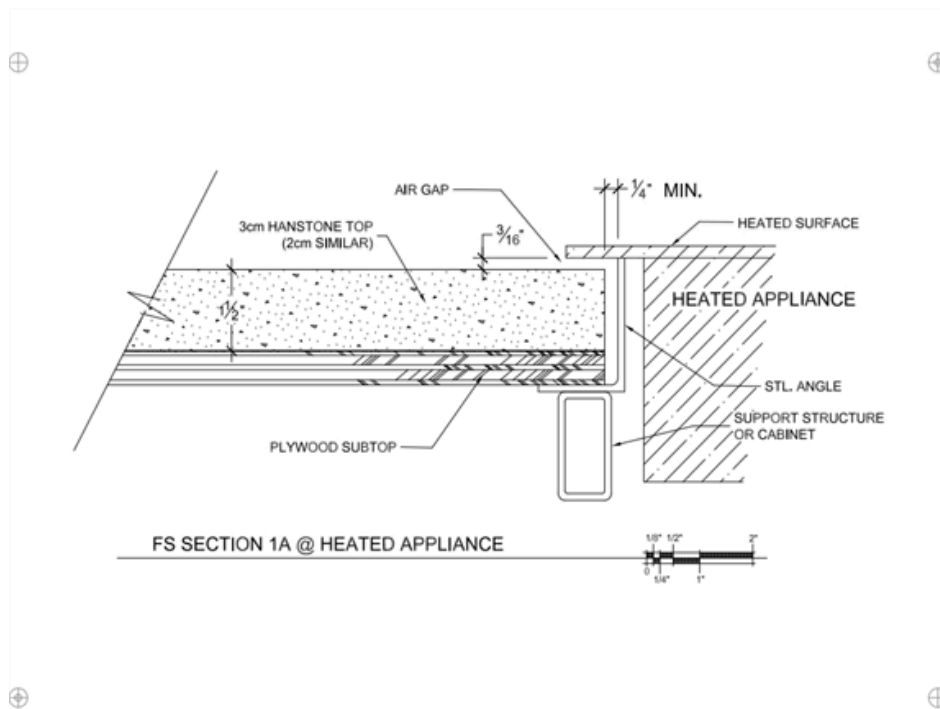

FS Section 1A - A heated appliance can be mounted with an air gap.

COMMERCIAL APPLICATIONS

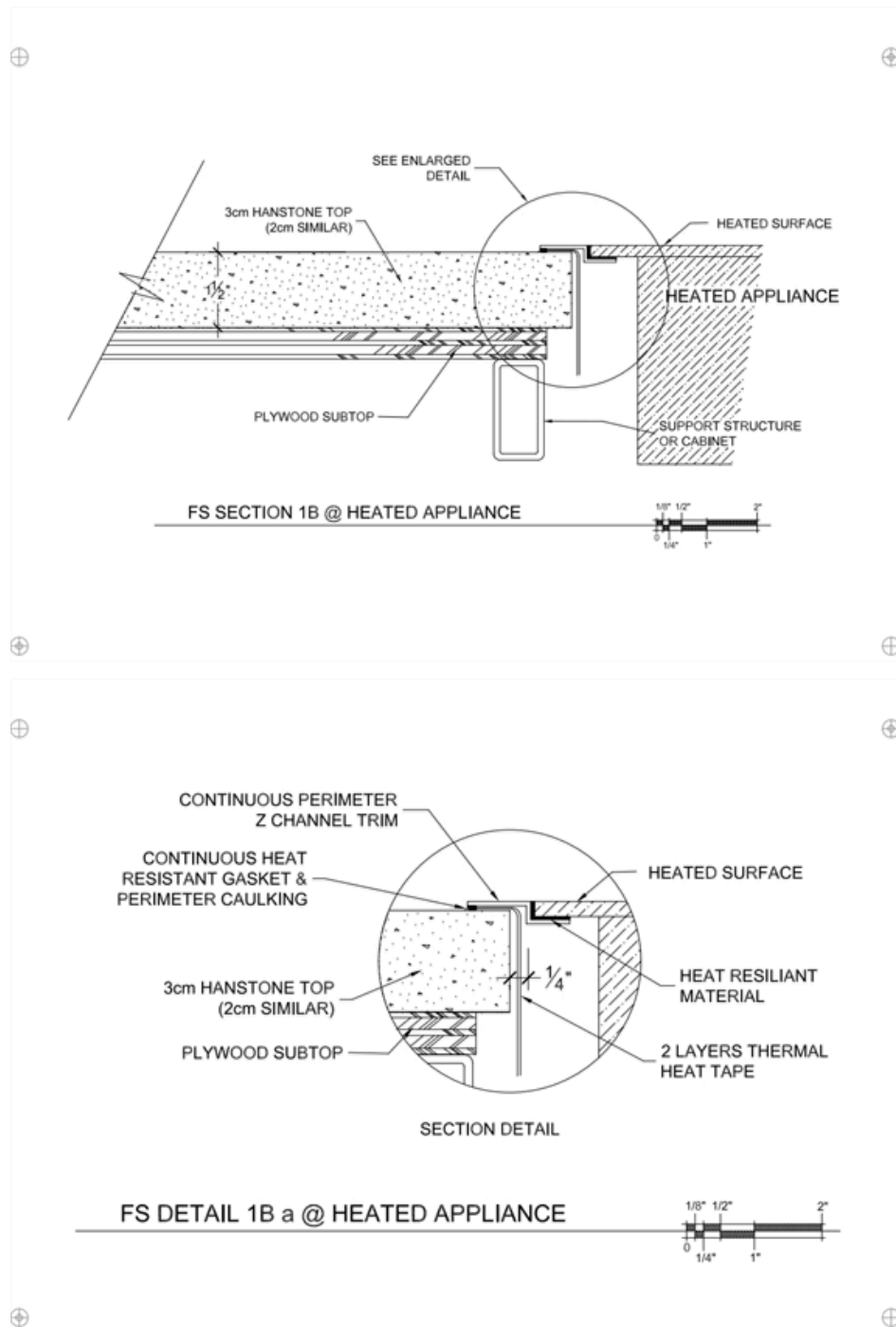

FS Section 1B – Heated appliances may also be installed using heat resilient materials and thermal tape.

COMMERCIAL APPLICATIONS

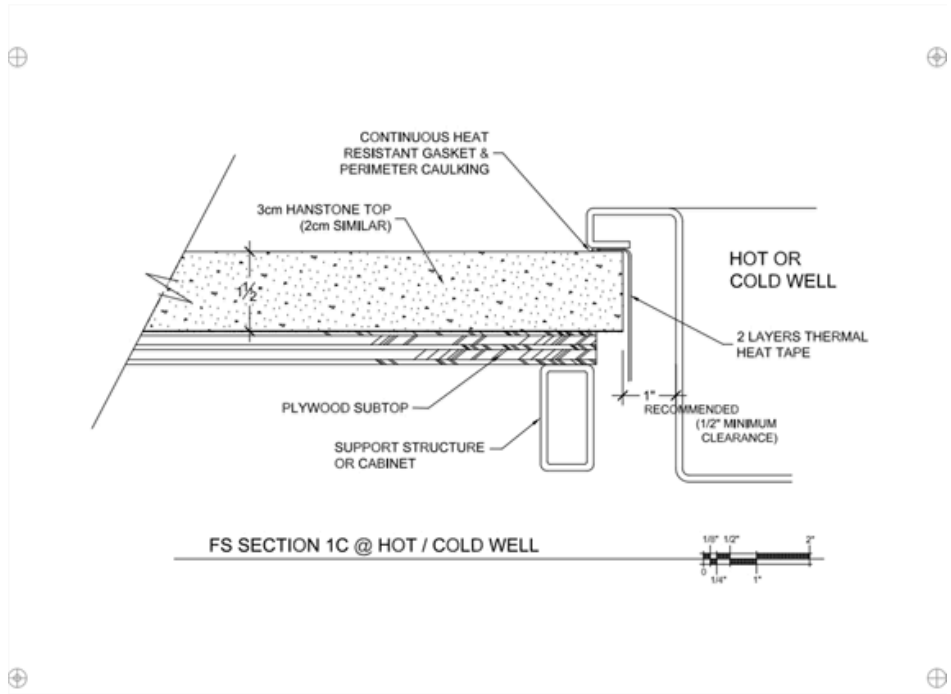

BACKSPLASH

- Check the splash for appropriate fit and then lay the top face down on the counter in the install position.
- Apply dots of silicone to the back of the splash on the ends and at 10' intervals along its entire length. Be careful to keep the upper dots low enough so the silicone doesn't ooze out the top when the splash is pressed against the wall.
- Roll the splash up and press onto the wall. Do not try to conform the splash to any curvatures in the wall as that would put undesirable stress on the stone.
- Cut outs for electrical outlets or other must have a 3/8" (10mm) radius in all 4 corners.
- HanStone recommends a minimum of 2' between an electric or induction stove or cooktop and a HanStone backsplash, and a minimum 10' from the center of a gas burner.
- Rear venting ovens or appliances should not be used as venting heat may discolor the backsplash.
- Caution must be taken: follow all manufactures recommendations.

***IF CRACKING OR DISCOLOURATION OCCURS DUE TO HEAT, IT WILL NOT BE COVERED UNDER WARRANTY. HANSTONE QUARTZ IS NOT RECOMMENDED NEAR A HEAT SOURCE BECAUSE CRACKING OR DISCOLOURATION MAY OCCUR.**

WALL/WET APPLICATION

HanStone Quartz can be used for wall cladding and wet applications but has some requirements. Walls must be stable and strong, and all applicable laws, engineering practices, building codes and regulations must be followed. It is recommended to always consult with a qualified individual. Hanstone neither assumes, nor will accept responsibility for any of the design, safety, or technical needs of the project application.

SPECIFICATIONS

- HanStone must be installed either directly on to a floor substrate or using anchors or bottom support that is sufficient to completely support the weight of the material used.
- HanStone is not a structural material and should not be used as such. Stone should not support stone.
- HanStone wall panels must be bonded to the backer board and the backer board must completely cover 100% of the backside of the panel.
- There must be a minimum 1/8" gap between the ceiling and HanStone wall panel to allow for expansion.
- All walls/surfaces must be true and level within 1/8" over 10 feet.
- Max. allowable deflection is L/360 and should be uniform over the length of the span.
- The use of latex thin-set mortar or epoxy adhesive and grout is recommended for wall applications.
- Bedding and grouting mortars used should be weather, frost, shock, and chemical-resistant.

All grout and mortars must meet the following requirements:

Compressive Strength: Thick-bed mortar	Min. 3000 PSI
Compressive Strength: Thin-bed mortar	Min. 500 PSI
Tensile Strength: Thin-bed, bonding, grouting mortars	Min. 500 PSI
Water Absorption:	4%
Ozone Resistance:	200 hrs @ 200ppm -No loss of strength
Smoke contribution Factor:	0
Flame contribution Factor:	0

WALL/WET APPLICATION

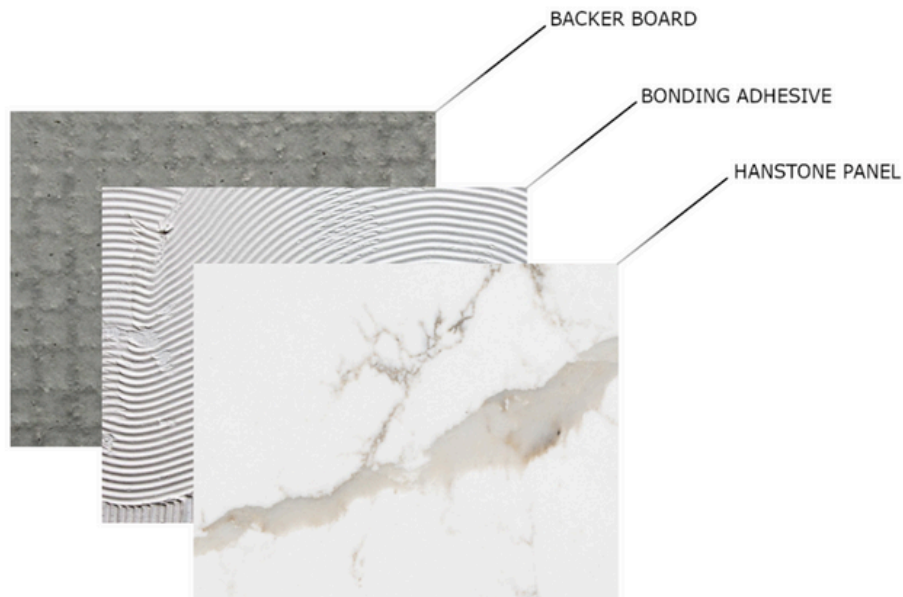

- With the proper preparation and adhesive choice, HanStone Quartz can be applied over concrete, masonry-type surfaces, gypsum wallboard, waterproof membrane, plasters, cement board, plywood, and steel.
- All adhesives, mortars, and bonding agents must be removed from the quartz surface immediately to avoid surface damage. HanStone will not be held responsible for any damage caused to the surface.
- HanStone is not a suitable replacement for a waterproof barrier, and one may still be needed depending on application.
- The installation professional is responsible for ensuring all dust, oil, grease, paint, wax, adhesive or other contaminants are cleaned from both surfaces before bonding HanStone to any type of material.
- It is recommended that all mortar additives, epoxy adhesives, and grouts be from one manufacturer to ensure ease of use and compatibility.
- Supports must be left in place for at least 24 hours (or the manufacturers recommended curing time) to allow the bonding adhesive to fully cure.
- It is recommended that the manufacturer's instructions are followed for the proper use of all bonding and grouting adhesives.
- Always practice safe working procedures and follow all applicable laws, building codes and regulations. Consulting with a qualified engineer or individual is always recommended.

SINKS

- Sink cut out corners should always have a minimum 3/8" (10mm) radius to avoid stress cracks forming.
- Sink bowls may be set anytime, but we recommend dry setting under-mount sinks prior to deck installation to confirm fit.
- When installing undermount sinks, it is highly recommended to use either a sink setter or sink harness type product. These will help to support some of the weight of the sink and avoid unnecessary repairs to fallen or separating sinks.
- 100% silicone should be used around the full edge of the sink to create a strong, watertight bond.

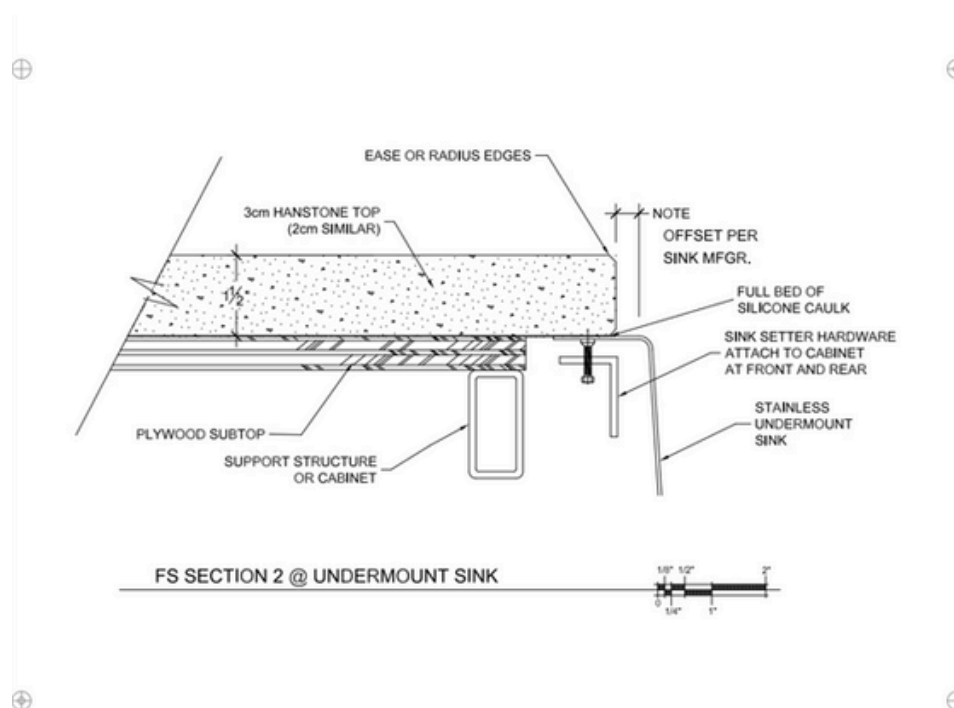

CLEAN UP

Care must be taken when using any type of harsh chemical in conjunction with HanStone, and solvents are no exception. Err on the side of caution by using any solvent sparingly and diluted (instead of full strength) whenever possible. Wipe up any spilled solvent immediately and do not allow solvent containers, bottles, sponges, or saturated rags to sit on the quartz countertop surface.

Avoid exposing HanStone to any strong chemicals and solvents.

CHEMICALS TO AVOID

◇ Solvents such as Acetone, nail polish remover, Xylene, Methyl Ethyl Ketone, paint or lacquer thinner, and others.

Acetone should never be used due to the possibility of damage to the surface of the HanStone material. Any damages caused by Acetone or other harsh chemicals or abrasives will void any possibility for warranty claim approval.

RECOMMENDED SOLVENTS FOR USE IN FABRICATION AND INSTALLATION PROCESSES'

◇ Denatured Alcohol, Methyl Hydrate, Methanol, Rubbing alcohol, Isopropyl alcohol.

- Use solvent sparingly.
- Do not pour solvent directly onto the countertop. Pour solvent on a clean rag and wipe the HanStone surface with the rag.
- Wipe up any spilled solvent immediately and rinse thoroughly with water.
- Do not place containers of solvent directly on the HanStone countertop.
- Use diluted solvent instead of concentrated whenever possible.
- Do not allow rags soaked in solvent to sit on the countertop surface.
- Some chemicals are more harmful to the HanStone surface than others. Concentrations and time of exposure are also important factors.
- Never use or recommend abrasive cleaners such as Vim, Magic Eraser or similar. They may cause irreversible damage to the surface.

Visit www.HanStone.ca for Care and Maintenance recommendations.

HanStone has developed these guidelines in order to produce the best results possible. Failure to follow these guidelines, and any resulting customer dissatisfaction, will become the sole responsibility of the fabricator.

SEE MORE ONLINE AT
WWW.HANSTONE.CA

CONNECT WITH US @HANSTONECA



HANSTONE CANADA

TOLL FREE NUMBER: +1 844.331.2428

EMAIL: INFO@HANSTONE.CA

SHOWROOMS & WAREHOUSES

LONDON | BURLINGTON | MONTRÉAL | CALGARY | VANCOUVER



June 2024